



## JETSPRAY

Compressed air & water spray humidifier  
Guaranteed drip free

Humidification and Evaporative Cooling

 **condair**

### JetSpray panel

An IP54 rated cabinet with easily accessible internal components and all electronic elements housed in a separate compartment above the water and air pipes.

### Power supply

Single phase power, 230V/50Hz or 110V/60Hz, max 210W power consumption (excluding air compressor).

### Remote user interface

Backlit digital multilingual display with keypad giving control and information on operation, commissioning, service requirements and fault diagnostics. Can be located up to 100m from the JetSpray panel. The system can also be controlled via BMS.

### Compressed air supply

Ensures rapid moisture evaporation, highly directional sprays with no risk of drips. The JetSpray uses at least 30% less compressed air than any other air and water atomising humidifier.

### Water supply

The JetSpray can operate on any potable water quality without the need for a demineralised supply, minimising water consumption.



# JetSpray

Compressed air & water spray humidifier



### Self-cleaning nozzles

Precision engineered nozzles with a 10-year warranty offer long life, minimal maintenance and are intrinsically safe with no required electrical supply.

### Humidity sensor

A single in-room humidistat or up to three averaging sensors can be used to monitor room conditions and provide accurate humidity control.

### Drain

Automated drain cycles ensure water cannot remain in the system to stagnate.

### PureFlo Ag+ silver ion water treatment

Silver is a powerful bacteriostatic agent with residual effects throughout the pipe work, promoting hygienic operation. UV water treatment is also available as an option.

The combination of compressed air and water allows the JetSpray to provide rapid moisture evaporation without the risk of wetting or drips.

The JetSpray is available in 60L/h and 600L/h capacity models. The 600L/h model is available with on/off control or fully modulating 0-100% output for highly accurate  $\pm 2\%$  RH humidity control.

Self-cleaning nozzles enable the humidifier to work with any potable water quality without the need for a demineralised supply. Its fan-free design ensures robust operation in dirty, dusty industrial environments with minimal maintenance.



Innovative design and quality construction allow JetSpray nozzles to carry a 10-year warranty

## High performance & robust operation

### **Why use compressed air?**

A compressed air and water humidifier offers guaranteed evaporation of the moisture into the atmosphere without any potential risk of drips. By forcing the water to mix with the air under pressure the sprays produced are rapidly absorbed and highly directional.

This makes the JetSpray ideal for cold temperature applications, such as cold stores, where the ambient humidity is often high and humidification less readily absorbed by the air.

As no fan unit is required to encourage evaporation, the JetSpray can reliably be used in very dusty and dirty industrial environments without frequent maintenance.

### **Low maintenance**

The JetSpray nozzle contains a self-cleaning mechanism that prevents blockages. A pin is forced through the nozzle orifice whenever the spray stops and is pushed back by the water pressure during operation. Unlike piston driven nozzle systems no lubrication of this mechanism is ever required and the only necessary maintenance of the nozzle line is to occasionally wipe the air caps to remove dust.

The nozzles are so robust in operation they carry a 10-year warranty.

### **Easy to install**

The JetSpray humidifier can be installed by any competent mechanical contractor. It incorporates standard plumbing fittings and pipe work, and doesn't need any special tools for installation. The system can be supplied with stainless steel, copper or plastic pipe work.

### **Consistent and accurate humidity control**

Unlike spot humidifiers that deliver high humidification outputs to the local area and rely on air movement to disperse the humidity, the JetSpray evenly introduces moisture across a room. The nozzles are strategically positioned to consistently spread the humidification with no areas of high or low humidity.

A fully modulating JetSpray provides 0-100% output enabling the humidifier to maintain more accurate humidity control than on/off systems at  $\pm 2\%RH$ .



Easy to install and service for any competent HVAC installer

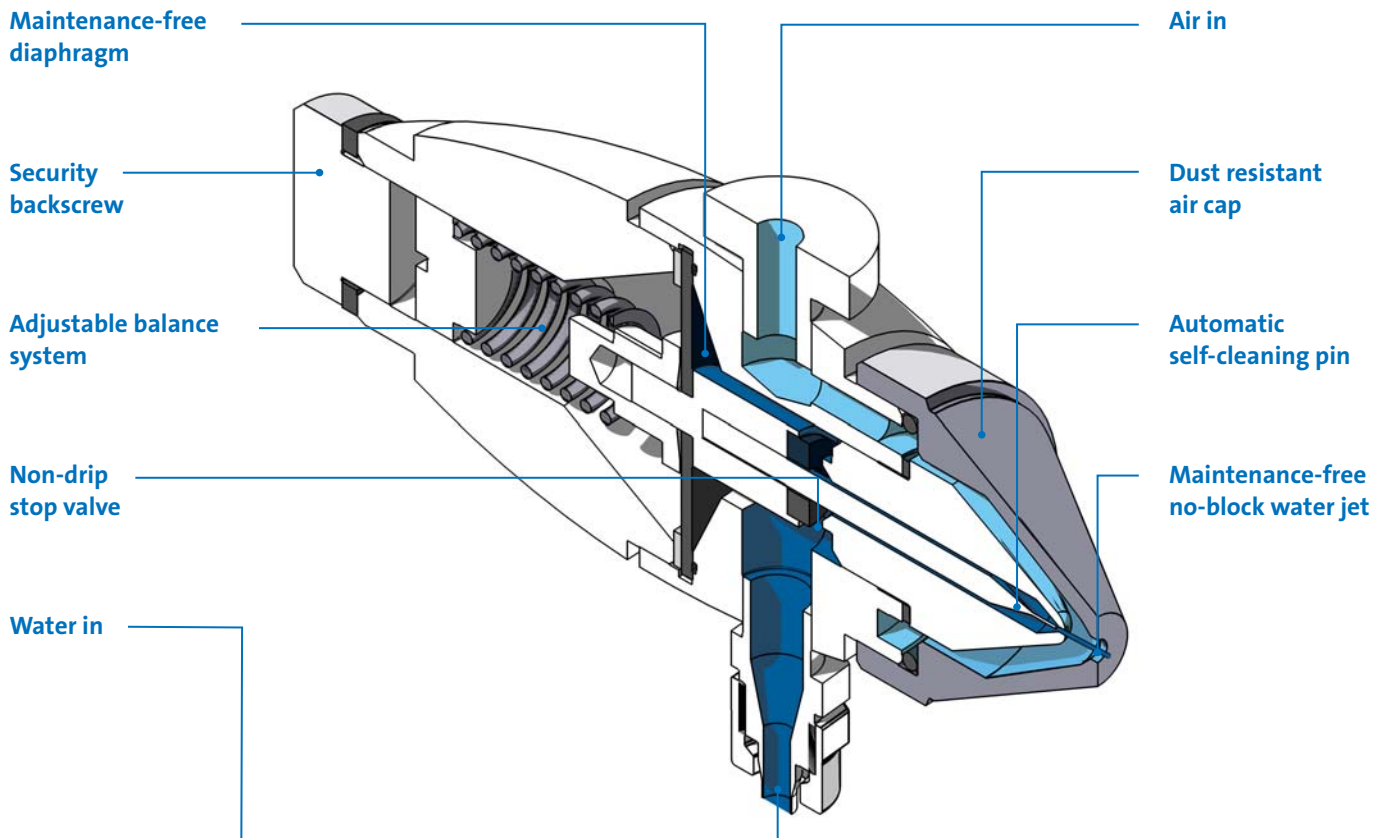



Proven technology across many industries for over 30 years

## Trusted

### Proven technology

The JetSpray has been humidifying factories and processing plants throughout the world for over 30 years and is trusted by the leading companies in many different industries including:

- Textile
- Printing
- Tobacco
- Cold storage
- Automotive
- Tea
- Crop storage
- Abattoirs
- Electronics
- Botanical gardens
- Pulp & paper

### Hygienic operation

The JetSpray is a sealed system with no open water tanks, minimising the risk of water contamination. Automatic purge and flush cycles ensure water cannot remain in the pipelines to stagnate. An air run-on feature leaves the pipe work dry at the end of the cycle.

PureFlo Ag+ silver ion water treatment is incorporated on the incoming water supply line. This is a bacteriostatic agent with residual effects throughout the pipe work, promoting hygienic operation.



# GOING GREEN CHECKLIST

DECREASE ENERGY USE  
INCREASE PROFITS



Energy efficient humidification with low operating costs

## Efficient

### **50% less water consumption**

The JetSpray can be operated on any type of potable water supply. This reduces water consumption by up to 50% compared to other spray humidifiers that need demineralised and softened water to prevent blockages at the nozzle.

### **30% less air consumption**

Unlike other air and water spray humidifiers that use the air pressure to push back the self-cleaning pin mechanism, the JetSpray nozzle uses the water pressure. This results in a lower required air pressure and a 30% reduction in compressed air consumption compared to other air and water systems.

### **Low energy & evaporative cooling**

In comparison to electric steam humidifiers the JetSpray consumes 90% less electrical energy to deliver the same amount of humidification. Rather than an electric heat source, the thermal energy of the air is used to evaporate the moisture. As well as humidification this causes an adiabatic cooling effect. For every kg of humidification approximately 680W of adiabatic cooling is also delivered, which can be a welcome benefit in a hot manufacturing environment.

## Typical system overview (600L/h)

- 1 JetSpray panel
- 2 Remote user interface
- 3 PureFlo Ag+ silver ion cartridge & particle filter (5 micron)
- 4 Air in
- 5 Water in
- 6 Air out
- 7 Water out
- 8 Drain
- 9 Nozzles
- 10 End of line
- 11 In-room humidity sensor

## Options

- Ultra-violet water steriliser
- Averaging in-room humidity sensor (up to 3 on 600L/h only)
- Water temperature alarm
- Air filter
- Air compressor
- RO water treatment

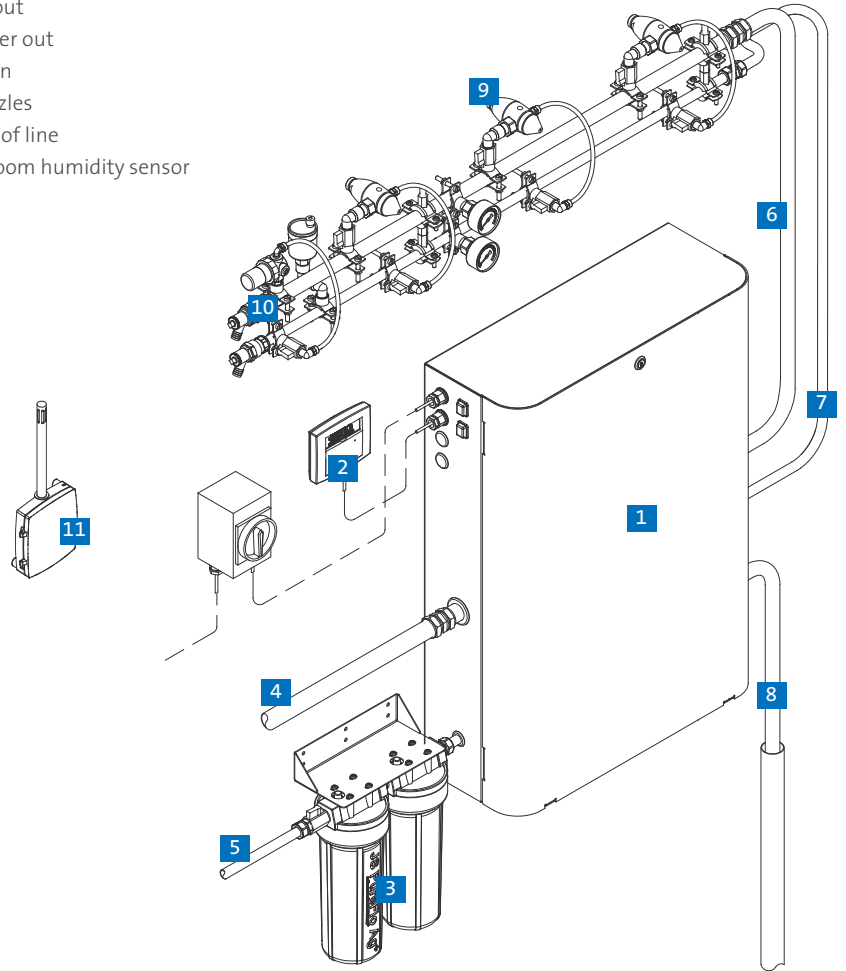

## Technical data

| Model   | Output kg/h | Modulating or on/off | Humidity control | Power consumption (ex. air compressor) W | Power supply  | Accreditations      |
|---------|-------------|----------------------|------------------|--|---------------|---------------------|
| JS60    | 2.5-60      | On/off               | ±4%RH            | 170                                      | 230Vac 110Vac | CE, UL Listed, WRAS |
| JS600DS | 2.5-600     | On/off               | ±3%RH            | 200                                      | 230Vac 110Vac |                     |
| JS600M  | 2.5-600     | Modulating           | ±2%RH            | 210                                      | 230Vac 110Vac |                     |

| Nozzle output (Litres/hr)   | 2.5  | 3.5  | 4.5  | 5.5  | 6.5  | 9    | 12   | 15   |
|---|------|------|------|------|------|------|------|------|
| SCFM air consumption per nozzle @ 2.2bar                          | 0.38 | 0.53 | 0.68 | 0.83 | 0.98 | 1.35 | 1.8  | 2.25 |
| CFM air consumption per nozzle. Free air delivery (0.33CFM/l)     | 0.83 | 1.16 | 1.49 | 1.82 | 2.15 | 2.97 | 3.96 | 4.95 |
| M3/hr air consumption per nozzle. Free air delivery (0.56M3/hr/l) | 1.4  | 1.96 | 2.52 | 3.08 | 3.65 | 5.05 | 6.73 | 8.41 |

Actual specifications may vary from those shown